

DESIGN DATA
MODEL BB-727272

PROCESS CHAMBER:

DIMENSIONS:

WORKING ENVELOPE: 72" W X 72" D X 72" H
INSIDE DIMENSIONS: 78" W X 80" D X 99" H

DESIGN LOAD: (Load of steel that will be heated to 750°F in one hour or less) 5,000 POUNDS
CART LOAD CAPACITY: 6,400 POUNDS
CART SIZE: 72" W X 72" L
OPERATING TEMPERATURE: 650°F TO 900°F
EXCESS TEMPERATURE SET POINT: 50°F-100°F OVER SET POINT
OVER TEMPERATURE SUPPRESSION SET POINT: 20°F -50°F OVER SET POINT
BURNER CAPACITY: 1,000,000 BTU'S

THERMAL OXIDIZER:

OPERATING TEMPERATURE RANGE: 1400°F-1600°F
RETENTION TIME AT TEMPERATURE: 0.5-1.0 SECONDS
APPROXIMATE CAPACITY: 55 LBS. PER HOUR
TEMPERATURE SUPPRESSION SET POINT: 100°F OVER SET POINT
EXCESS TEMPERATURE SET POINT. 1850°F
BURNER CAPACITY: 1,000,000 BTU'S
STACK LENGTH: 18' STANDARD
TOTAL HEIGHT (GROUND TO TOP OF STACK): 29'-2"

UTILITIES REQUIRED:

NATURAL GAS:

AT 7" INCHES WATER COLUMN (0.25 PSI) PRESSURE UNDER FLOW.
STATIC PRESSURE NOT TO EXCEED 14" W.C.
REGULATORS DO NOT FUNCTION PROPERLY BELOW 6"W.C.
MAXIMUM CAPACITY: 2,000 CFH (CUBIC FEET/ HOUR)
NORMAL USAGE: 1,200 CFH (CUBIC FEET/ HOUR)

ELECTRICAL:

DEDICATED 120V/ 1 PH/ 60 HZ SERVICE: 15 AMPS (OVEN)
DEDICATED 230V/ 3 PH/ 60 HZ SERVICE: 20 AMPS (SS BLOWER OPTIONAL)

WATER:

CONNECTION 3/4": 35-50 PSI UNDER FLOW
ONLY REQUIRED FOR OVER
TEMPERATURE CONDITIONS

PERFORMANCE WARRANTY:

PROPOSED EQUIPMENT IS WARRANTED TO BE CAPABLE OF OPERATING AT THE HEAT OUTPUT AND TEMPERATURE RANGE SHOWN ABOVE, PROVIDED PROPER UTILITIES ARE CONNECTED AND THAT THE EQUIPMENT IS PROPERLY MAINTAINED. THERMAL OXIDIZER CAPACITY RATING MAY VARY DUE TO TYPE OF COATING, LOADING CONFIGURATION, PROCESS TEMPERATURE SETTING AND CYCLE TIME.

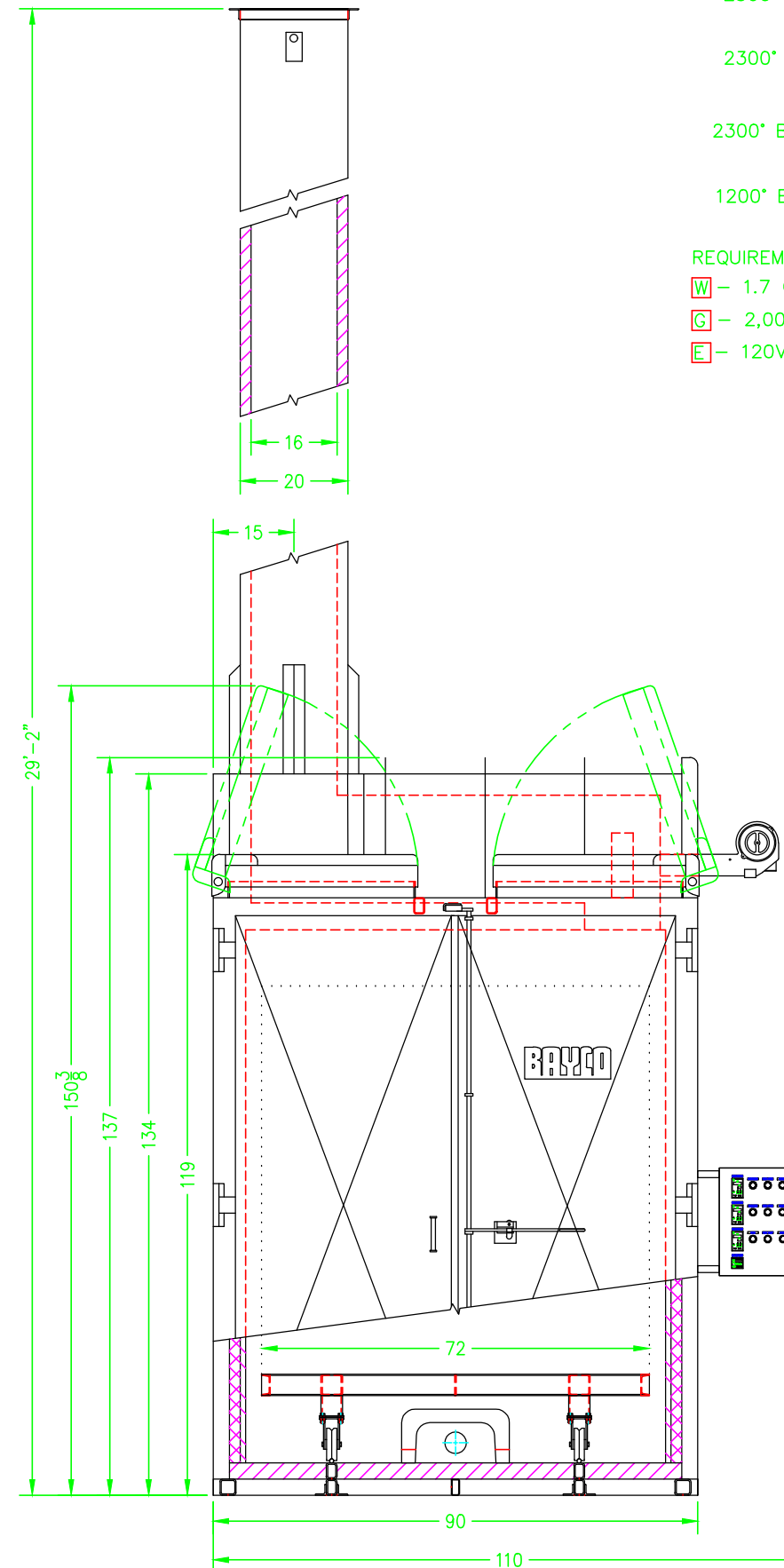
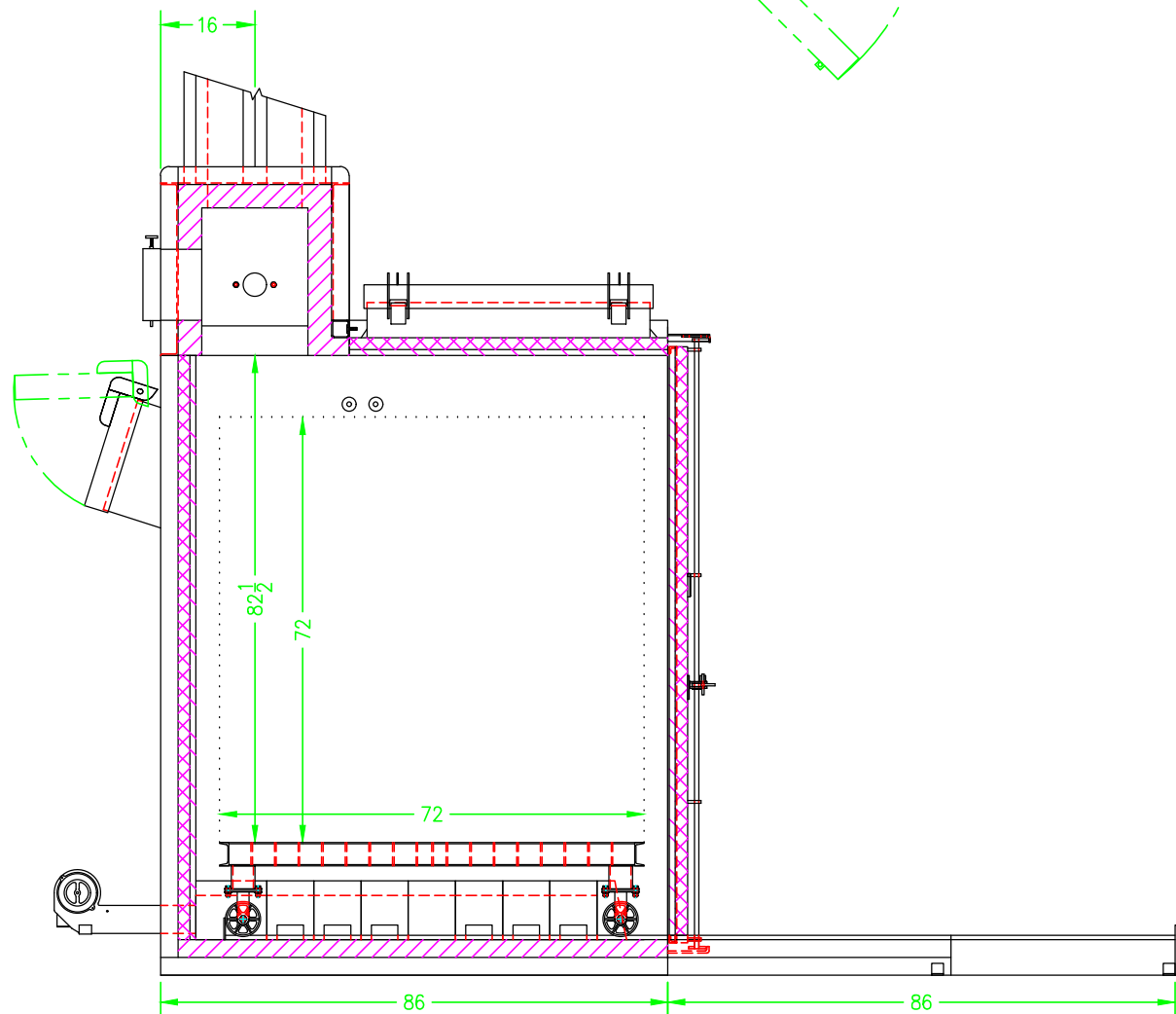
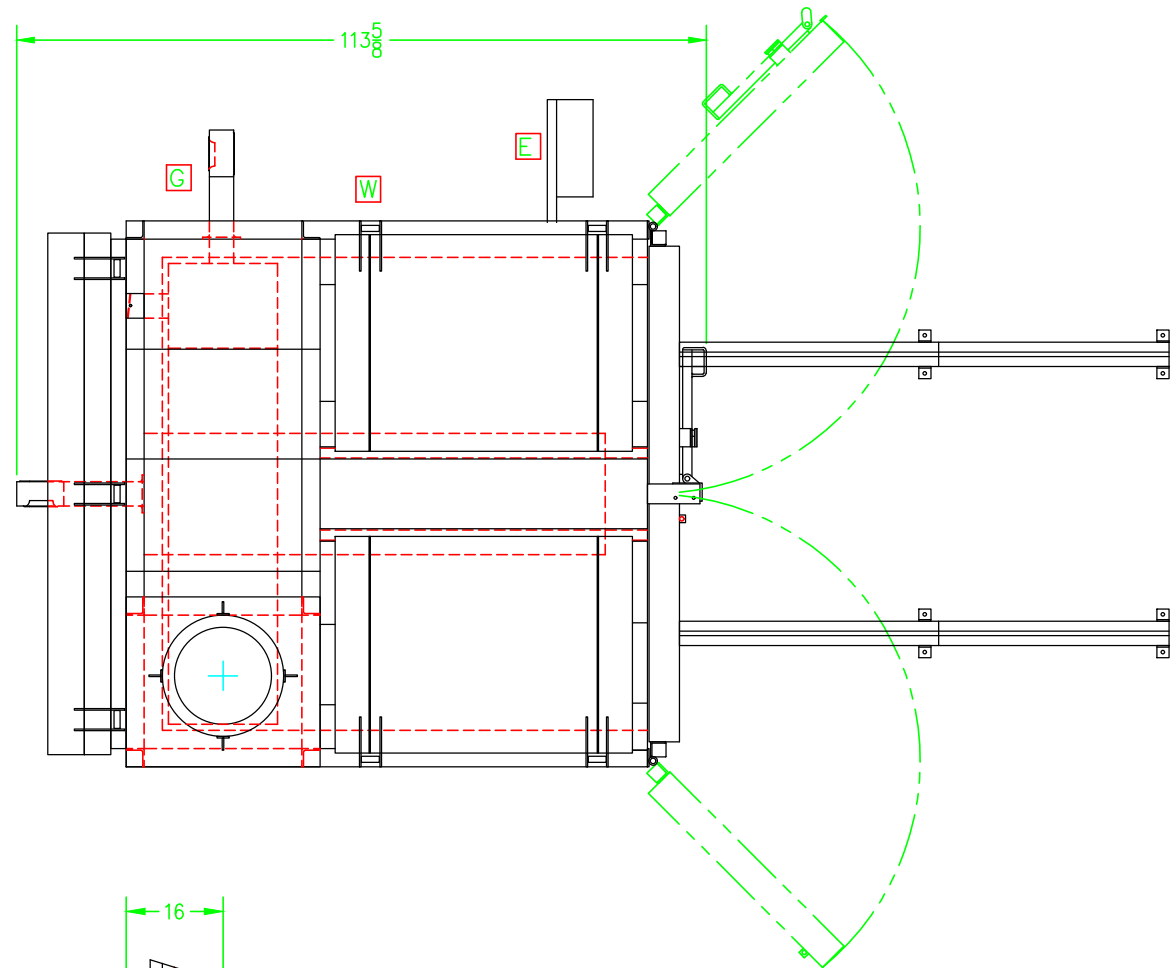

REFRACTORY

- 2500° CAST
- 2300° CAST
- 2300° BOARD
- 1200° BLOCK

REQUIREMENTS

- W** - 1.7 GPM AT 45 PSI
- G** - 2,000 CFH AT 7" WC NATURAL GAS
- E** - 120V 15A 60HZ 1PH SUPPLY

THIS CONCEPTUAL DRAWING IS PROVIDED TO ILLUSTRATE BASIC DESIGN AND APPROXIMATE OVER ALL DIMENSIONS.

THIS DRAWING IS PROPRIETARY INTELLECTUAL PROPERTY OF GUSPRO INC. AND IS NOT TO BE REPRODUCED OR DISTRIBUTED IN ANY MANNER WITHOUT THE EXPRESSED WRITTEN PERMISSION OF GUSPRO INC.

	OVEN NO.	DATE
	BB-727272	28/JUL/14
CUSTOMER'S NAME		
CUSTOMER'S ADDRESS		
DRAWN BY	APPROVED BY	REVISION DATE
J.M.S.		1/AUG/14

GUSPRO
INCORPORATED

DESIGN DATA
MODEL BB-727272

PROCESS CHAMBER:

DIMENSIONS:

WORKING ENVELOPE: 72" W X 72" D X 72" H
INSIDE DIMENSIONS: 78" W X 80" D X 99" H

DESIGN LOAD: (Load of steel that will be heated to 750°F in one hour or less) 5,000 POUNDS
CART LOAD CAPACITY: 6,400 POUNDS
CART SIZE: 72" W X 72" L
OPERATING TEMPERATURE: 650°F TO 900°F
EXCESS TEMPERATURE SET POINT: 50°F-100°F OVER SET POINT
OVER TEMPERATURE SUPPRESSION SET POINT: 20°F -50°F OVER SET POINT
BURNER CAPACITY: 1,000,000 BTU'S

THERMAL OXIDIZER:

OPERATING TEMPERATURE RANGE: 1400°F-1600°F
RETENTION TIME AT TEMPERATURE: 0.5-1.0 SECONDS
APPROXIMATE CAPACITY: 55 LBS. PER HOUR
TEMPERATURE SUPPRESSION SET POINT: 100°F OVER SET POINT
EXCESS TEMPERATURE SET POINT. 1850°F
BURNER CAPACITY: 1,000,000 BTU'S
STACK LENGTH: 18' STANDARD
TOTAL HEIGHT (GROUND TO TOP OF STACK): 29'-2"

UTILITIES REQUIRED:

LIQUID PROPANE GAS:

AT 11" INCHES WATER COLUMN (0.40 PSI) PRESSURE UNDER FLOW.
STATIC PRESSURE NOT TO EXCEED 14" W.C.
REGULATORS DO NOT FUNCTION PROPERLY BELOW 6" W.C.
MAXIMUM CAPACITY: 2,000,000 BTU/HR
NORMAL USAGE: 1,200,000 BTU/HR

ELECTRICAL:

DEDICATED 120V/ 1 PH/ 60 HZ SERVICE: 15 AMPS (OVEN)
DEDICATED 230V/ 3 PH/ 60 HZ SERVICE: 20 AMPS (SS BLOWER OPTIONAL)

WATER:



CONNECTION 3/4": 35-50 PSI UNDER FLOW
ONLY REQUIRED FOR OVER
TEMPERATURE CONDITIONS

PERFORMANCE WARRANTY:

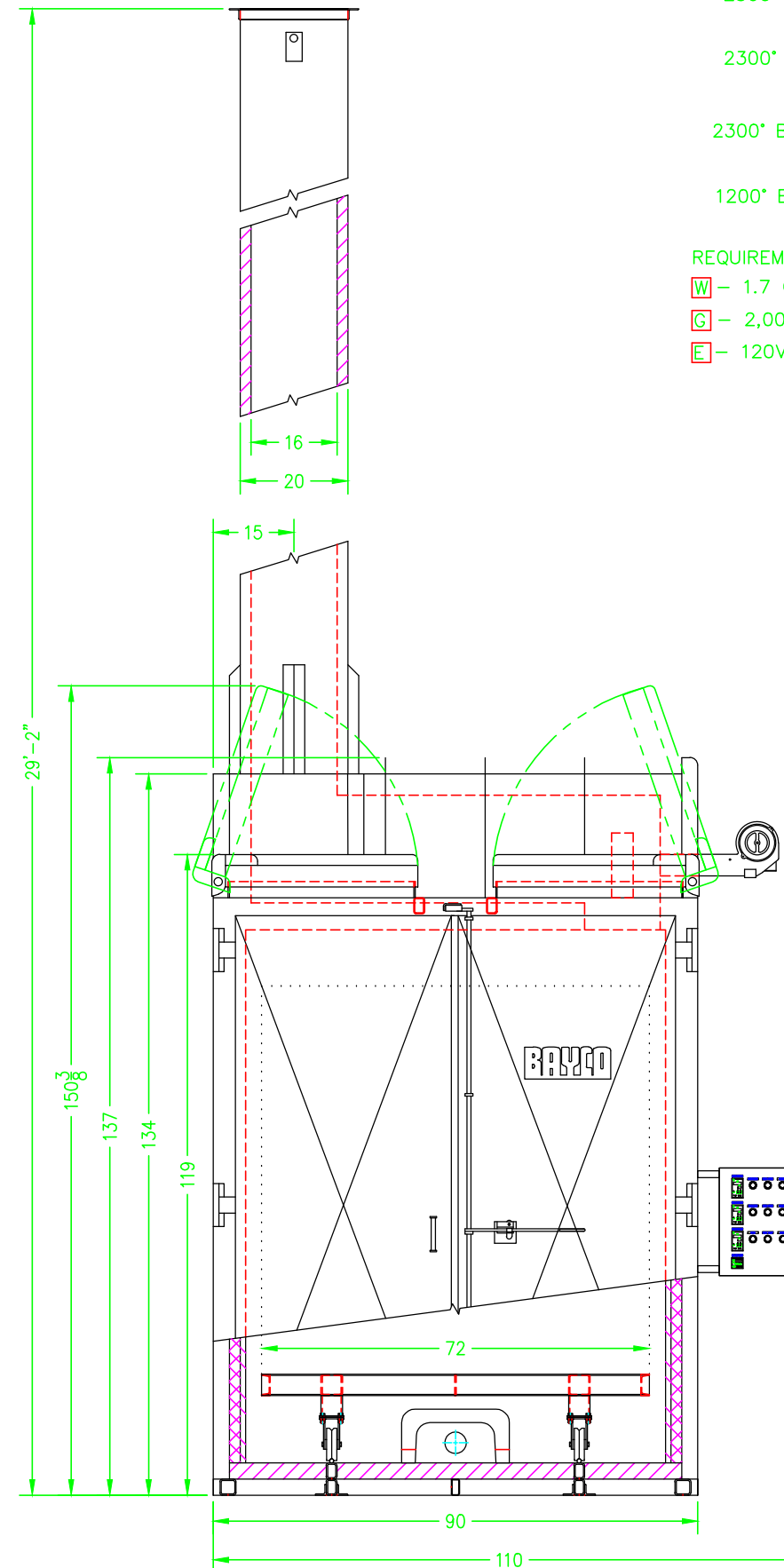
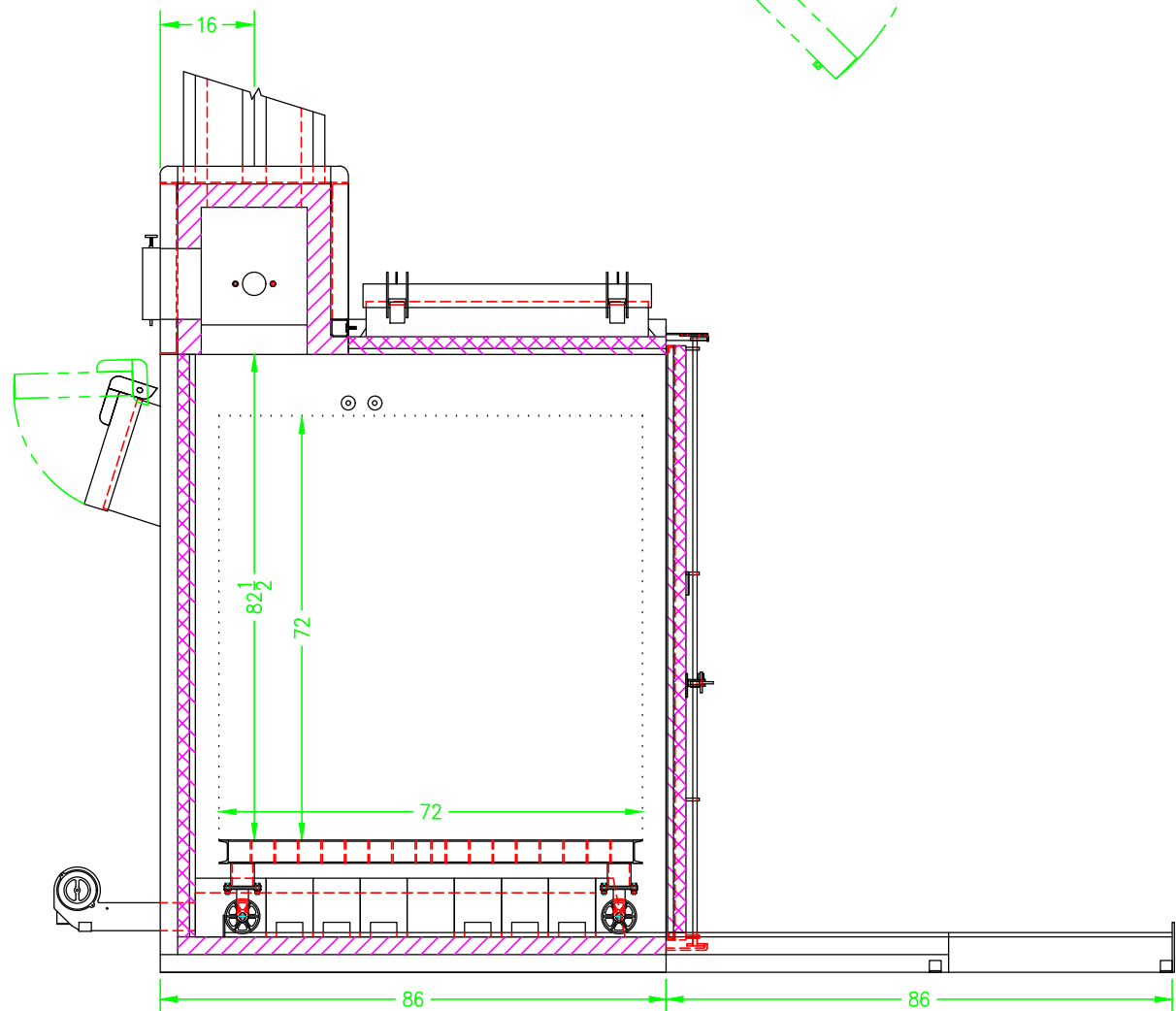
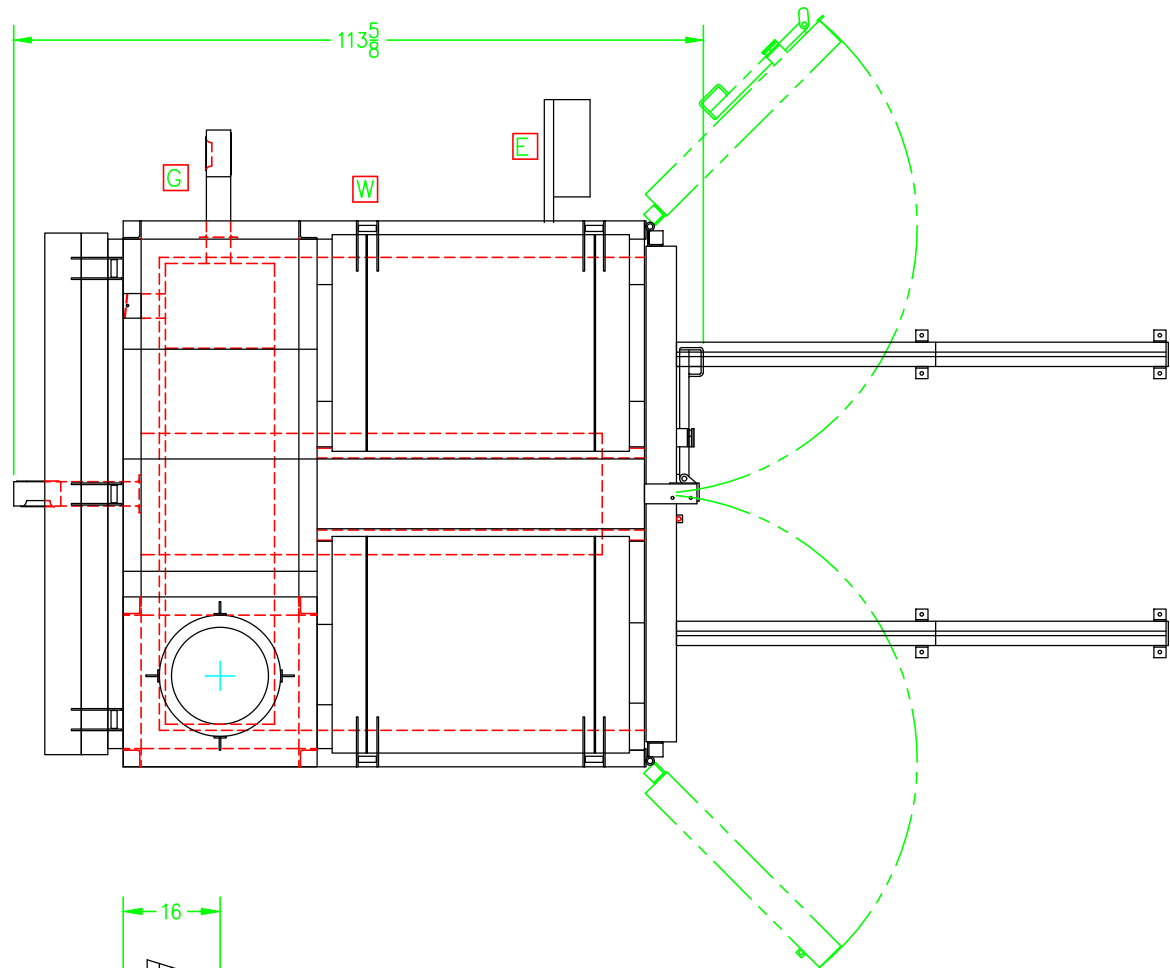
PROPOSED EQUIPMENT IS WARRANTED TO BE CAPABLE OF OPERATING AT THE HEAT OUTPUT AND TEMPERATURE RANGE SHOWN ABOVE, PROVIDED PROPER UTILITIES ARE CONNECTED AND THAT THE EQUIPMENT IS PROPERLY MAINTAINED. THERMAL OXIDIZER CAPACITY RATING MAY VARY DUE TO TYPE OF COATING, LOADING CONFIGURATION, PROCESS TEMPERATURE SETTING AND CYCLE TIME.

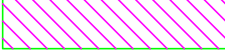
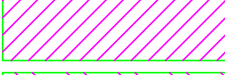
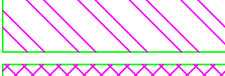

REFRACTORY

- 2500° CAST 
- 2300° CAST 
- 2300° BOARD 
- 1200° BLOCK 

REQUIREMENTS

- W** - 1.7 GPM AT 45 PSI
- G** - 2,000,000 BTU'S AT 11" WC LIQUID PROPANE
- E** - 120V 15A 60HZ 1PH SUPPLY

THIS CONCEPTUAL DRAWING IS PROVIDED TO ILLUSTRATE BASIC DESIGN AND APPROXIMATE OVER ALL DIMENSIONS.

THIS DRAWING IS PROPRIETARY INTELLECTUAL PROPERTY OF GUSPRO INC. AND IS NOT TO BE REPRODUCED OR DISTRIBUTED IN ANY MANNER WITHOUT THE EXPRESSED WRITTEN PERMISSION OF GUSPRO INC.

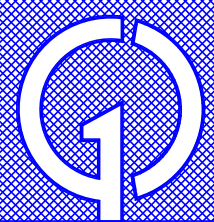
	OVEN NO.	DATE
	BB-727272	28/JUL/14
CUSTOMER'S NAME		
CUSTOMER'S ADDRESS		
DRAWN BY	APPROVED BY	REVISION DATE
J.M.S.		1/AUG/14

GUSPRO
INCORPORATED